

# MARCONIPHONE

## 950

### HMV 1750

Four-valve, plus rectifier, three waveband superhet radiograms with manual and push-button tuning. Sockets for extra speakers are provided with an internal and external silencing switch. Suitable for operation from DC mains 200-250v and AC mains 200-250v, 25-60 cycles. Marketed 1940 by Marconiphone and Gramophone Companies, Hayes, Middlesex.

THE aerial input is via C1 on all wavebands and via C1 and C2 on SW to the coupling coils L1, L3, L5. Image rejection on LW is provided by C3. For manual tuning the secondaries L2,

L4 and L6 are tuned by the VC1 section of the two-gang condenser while on push-button tuning trimmers T9 to T13 are shunted across the appropriate coils.

The signal is fed to the control grid of the frequency changer V1, which is AVC controlled permanently biased by the cathode resistance R2, decoupled by C6. Screen grid potentials for both V1 and V2 are obtained from R4 decoupled by C15.

The oscillator section of V1 employs a L8, L10 and L11 manually by the VC2 section of the ganged condenser and has separate variable inductance iron-dust cored coils L12-L16 for press-button tuning. R3 and C8 are the grid leak and condenser with C11 as the coupling capacity between the grid and anode circuits on push-button tuning.

An iron-dust cored IF transformer, L17-L18, transfers the signal to the grid of the amplifier, V2. This valve is AVC controlled and is permanently biased by R7 decoupled by C16.

A second IF transformer, L19-L20, passes on the signal to the signal diode of the double-diode-triode, V3. The

load is R11 and remaining IF is filtered out by R10 and C19. LF is coupled via C20 to the volume control VR1, from whence it is conveyed to the grid of the triode section of V3.

On gramophone the low-impedance pickup (800 ohms DC) is transformer coupled to the volume control circuit by the pickup transformer L21, L22. A tone correcting and input limiting network is provided by R8, R9 and C17 across L21.

The AVC diode of V3 is fed from the anode circuit of V2 via C21, the load resistances being R13 and R14. Both V1 and V2 grid circuits are fed from the junction of R13 and R14 with decoupling components R1, C5 and C22.

The anode circuit of V3 comprises the HF filter R15, C26; the LF coupling components R16, C24; and the decoupling components R17, C25. The LF signal is fed to the grid of the pentode output valve V4, via the grid stopper, R18, while R19 is the grid to cathode resistance.

V4 is biased by R20 decoupled by C27 and a permanent degree of tone correction

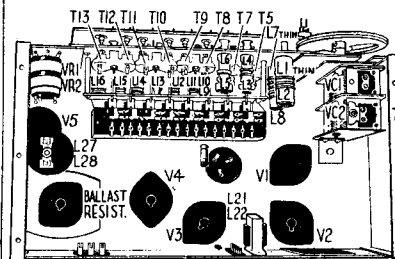
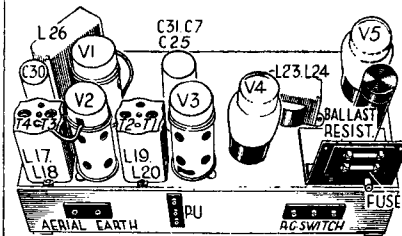

### VALVE READINGS

V	Type	Electrode	Volts	Mas
1	X65	Anode	205	2
		Osc anode	80	3.2
		Screen	95	3.5
		Cathode	3	8.7
2	KTW61	Anode	205	6.7
		Screen	80	2
		Cathode	3	8.7
3	DH63	Anode	120	7
		Cathode	1.5	.7
4	KT35	Anode	193	52
		Screen	205	8
		Cathode	12	60
5	U31	Cathode	215	79

Pilot lamp, 6v, .3 amp, MES.  
Measurements taken on 220v.  
AC mains on MW, no signal input.

condensers C30 and C31. All the valve heaters are in series with the ballast resistance, R23, and with R24 the pilot lamp shunt. R22 is a surge limiter in the anode circuit of V5 on the highest voltage range.

The mains are HF filtered by L27, L38, C33 and a 1.25 amp fuse is included in each mains lead.

The motor circuit incorporates its own HF filter coils, L29, L30. The motor is a low voltage universal type with a series dropping resistance R25, R26, R27.

The tapping on the motor resistance is adjusted with regard to the periodicity of the mains supply in addition to its voltage.

Note.—In the original instruments the volume control, VR1, the tone control, VR2, and the mains on-off switch, S1, were all combined in one component. Subsequent instruments bearing a suffix "A" have separate volume and tone controls, the latter being mounted at the side of the cabinet, while the mains on-off switch is a single pole type combined with the volume control.

### GANGING

IF Circuits.—Switch receiver to MW tone control fully clockwise, volume control to maximum and gang condenser to minimum. Inject a 465kc signal via a .1 mfd condenser to the top cap of V1, leaving the grid connection in position.

Adjust T1, T2, T3 and T4 in that order for maximum output.

Calibration Check.—With gang at minimum capacity check that the pointer is opposite the 192m mark on the MW scale. If necessary, slide pointer up or down the drive wire.

SW Band.—Switch receiver to SW and inject a 50m signal via a dummy aerial to the aerial and earth sockets. Set the tuning pointer of the receiver to 50m and adjust the loops in L8 and L2 for maximum output.

Continued on page vi

is effected by C28. A variable tone control is provided by VR2 and C29 across the primary, L23, of the output transformer. The secondary, L24, of this transformer has a permanent load resistance, R21, across it and the extra loudspeaker sockets.

HT supply comes from the half-wave rectifier V5, smoothing choke L26, and

The receivers are AC-DC radiograms with push-button stations.

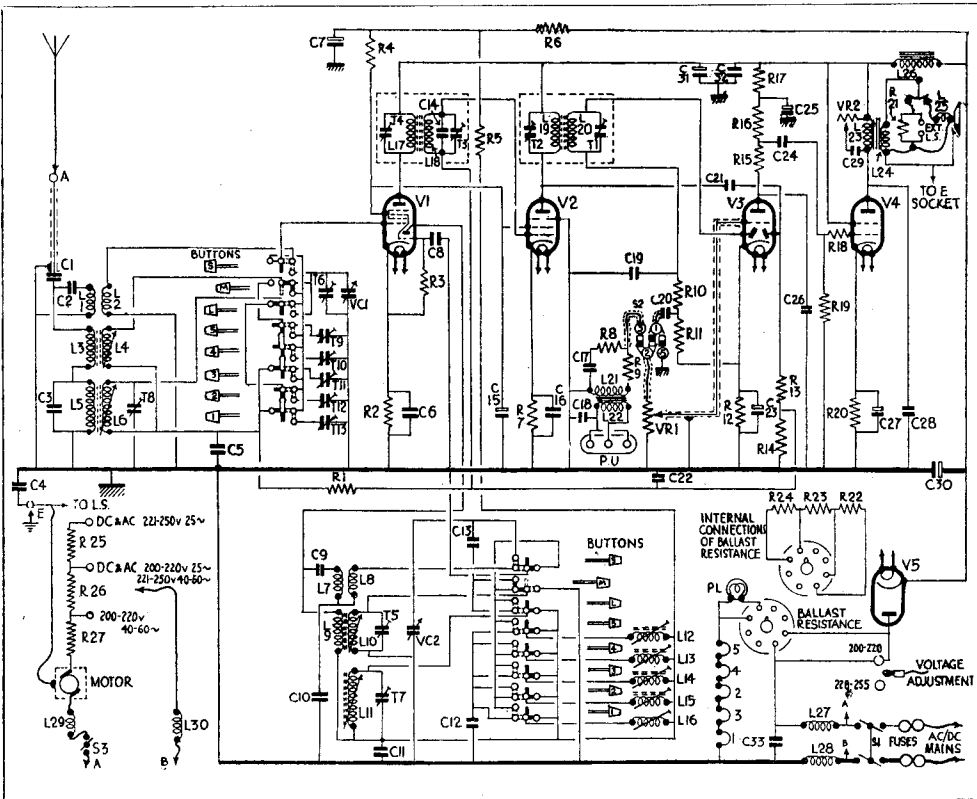

### CONDENSERS

C	Mfds
1	.0005
2	.000035
3	.0005
4	.01
5	.05
6	.05
7	.4
8	.000075
9	.00005
10	.005
11	.00035
12	.00023
13	.0005
14	.00025
15	.2
16	.05
17	.023
18	.005
19	.0001
20	.05
21	.0001
22	.05
23	.50
24	.05
25	.4
26	.0005
27	.25
28	.0023
29	.15
30	.16
31	.32
32	.1
33	.01

### RESISTANCES

R	Ohms	R	Ohms
1	230,000	16	50,000
2	350	17	10,000
3	50,000	18	23,000
4	5,000	19	230,000
5	5,000	20	200
6	10,000	21	50
7	350	22	52
8	23,000	23	440
9	50,000	24	21
10	100,000	25	350
11	500,000	26	100
12	2,300	27	700
13	500,000	VR1	.2 meg.
14	1.5 meg.	VR2	50,000
15	50,000		

### WINDINGS

L	Ohms	L	Ohms
1	.7	16	10
2	.1	17	6.5
3	.24	18	2.75
4	2.25	19	.4
5	.59	20	.4
6	17.5	21	2.080
7	.8	22	170
8	.1	23	230
9	1.75	24	Very low
10	.3	25	.4
11	7.5	26	150
12	3.5	27	.3
13	5.5	28	.3
14	5.5	29	.4
15	10	30	.4

# HMV 1107

Four-valve, plus rectifier, three-waveband superhet table model. Wavechanging is effected by three push-buttons, but tuning is manual. Provision is made for connecting a pickup and extra loudspeaker. For operation from 195-255v mains, 50-100 cycles. Marketed 1940 by the Gamophone Co., Ltd, Hayes, Middlesex.

THE Model 1107 incorporates the basic chassis and circuit of the Models 1106 and 1504 reviewed elsewhere. As will be seen from the circuit diagram there are no press-button tuning circuits, but wave-changing is effected by a triple push-button switch assembly. The other circuit arrangements are so similar to the

Model 1106 that a repetition of the circuit description is not necessary.

### GANGING

**IF Circuits.**—Inject signal to V2 top cap (via a 0.1 mfd condenser), leaving grid connexion in position, and chassis.

Connect 35,000 ohm resistance and 0.05 mfd condenser in series across L14 (or between "hot" side of coil and chassis, whichever is more convenient).

Tune oscillator exactly to 465kc (645.2m). Adjust L15 for maximum output.

Damp L15 as above and trim L14 for maximum output.

Connect oscillator leads to top cap V1 (via 0.1 mfd condenser) and chassis. Damp L12 as above. Trim L13 for maximum output.

Damp L13 and trim L12 for maximum output.

**SW Band.**—Before commencing ganging operations on the HF circuits check the position of the wave-scale and pointer. Turn gang condenser to minimum.

See that the pointer registers accurately on the 192m mark. If adjustment is necessary, pointer can be slid up or down the drive wire.

Connect oscillator to A and E sockets via a SW dummy aerial. Switch receiver to SW, volume to maximum, and tone control fully clockwise.

Inject signal of 50m (6mc), set tuning pointer to 50m and adjust loops in L8 and L2 for maximum output. Repeat several times if necessary until no further increase in output can be obtained.

Check that receiver will tune in 16.8m (17.86mc).

**MW Band.**—Set gang to minimum, and tune oscillator to exactly 192m. (1,562kc). Adjust T1 for maximum output.

Set oscillator and receiver (by scale) to 210m (1,429kc), and adjust T2 for maximum output.

Set oscillator and receiver (by scale) to 510m (588.2kc), and adjust the cores of L10 and L4 for maximum.

Repeat above operations several times if necessary.

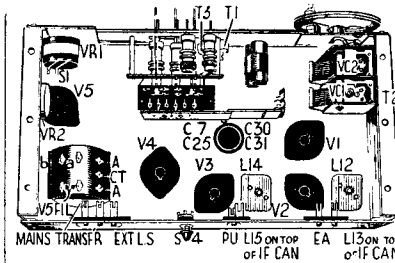

The under-chassis layout for model 1107.

**LW Band.**—Set oscillator and receiver to 720m (416.7kc) and adjust T3 for maximum output.

Set oscillator and receiver to 1,850m (162.2kc), and adjust L11 for maximum output.

Set oscillator and receiver to 1,400m (214.3kc), and adjust L6 for maximum output.

Repeat adjustment of T3.

After ganging do not alter position of pointer in relation to the gang condenser.

### VALVE READINGS

V	Type	Electrode	Volts	Mas
1	X61M	Anode	260	3.3
		Osc anode	95	5
		Screen	85	3.7
2	KTW61M	Cathode	2.7	—
		Anode	260	8
		Screen	85	2.5
3	DH63M	Cathode	3.5	—
		Anode	105	.5
		Screen	1.1	—
4	KT6I	Anode	245	42
		Screen	260	8
		Cathode	5	—
5	U50	Cathode	350	80
		Anode	—	—

### RESISTANCES

R	Ohms	R	Ohms
1	500,000	11	750,000
2	230	12	750,000
3	15,000	13	75,000
4	15,000	14	100,000
5	50,000	15	10,000
6	23,000	16	350,000
7	350	17	23,000
8	350,000	18	100
9	350,000	VR1	2 meg
10	2,300	VR2	50,000

### WINDINGS

L	Ohms	L	Ohms
1	.7	14	5
2	Very low	15	5
3	.24	16	370
4	2.25	17	.5
5	.59	18	—
6	17.5	19	4
7	.8	20	950
8	Very low	21	Very low
9	1.75	22	315+315
10	3	23	Very low
11	7.5	24	30 (total)
12	5		

Circuit description is similar to that for model 1106 on page iv.

### CONDENSERS

C	Mfds
1	50 mmfds
2	.0005
3	5 mmfds
4	.0001
5	.05
6	.05
7	.4
8	75 mmfds
9	50 mmfds
10	.005
11	.00025
12	.0005
13	.05
14	.0002
15	.0002
16	.05
17	.0002
18	.0002
19	.0001
20	.05
21	.50
22	.0001
23	.05
24	.05
25	.4
26	.00023*
27	.0023
28	.05
29	.15
30	.8
31	2.3 mmfds
32	2.3 mmfds

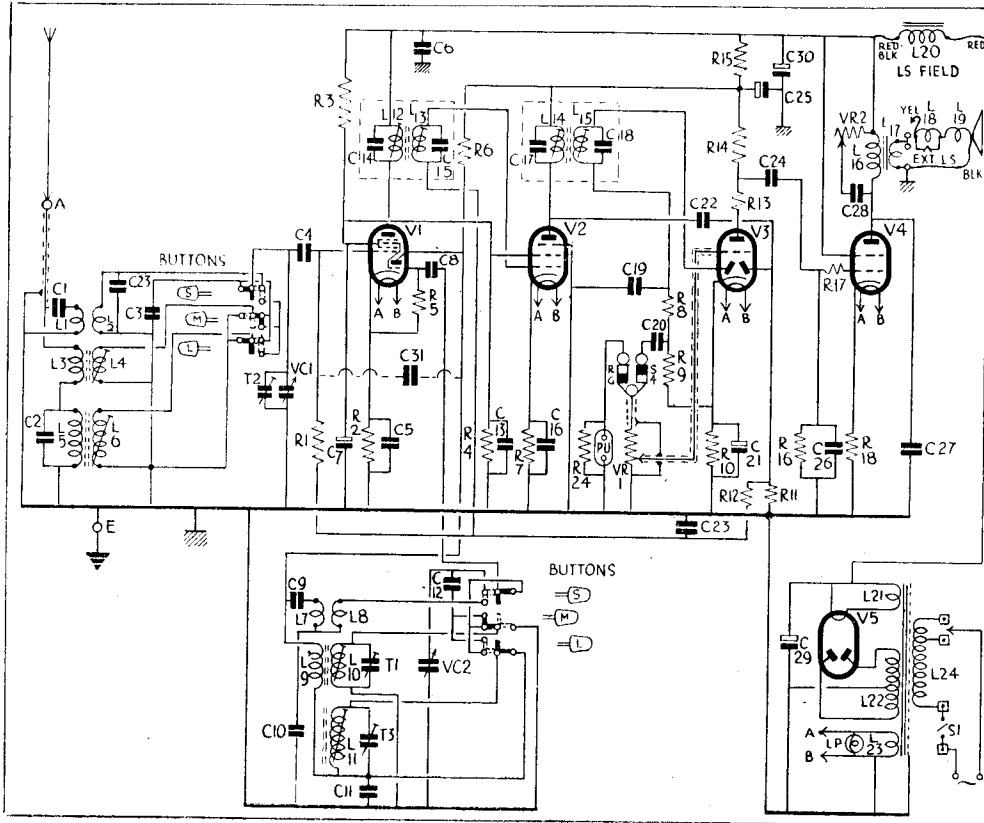

# HMV 1106, 1504

Continued from page iv.

of the wave-scale and pointer. Turn gang to minimum and see that the pointer registers accurately on the 192m mark.

If adjustment is necessary, pointer can be slid up or down the drive wire.

**SW Band.**—Connect oscillator to A and E sockets via a SW dummy aerial device. Set receiver to SW, volume fully up and tone fully clockwise.

Inject signal of 50m (6mc), set tuning pointer to 50m, and adjust loops in L8 and L2 for maximum output. Repeat several times if necessary until no further increase in output can be obtained.

Check that receiver will tune in 16.8m (17.86mc).

**MW Band.**—Set gang to minimum, and tune oscillator to exactly 192m (1,562.5kc). Adjust T8 for maximum output.

Set oscillator and receiver (by scale) to 210m (1,429kc) and adjust T7 for maximum output.

Set oscillator and receiver (by scale) to 510m (588kc) and adjust the cores of L10 and L4 for maximum. Unless either of these coils has been changed very little adjustment should be necessary.

Repeat above operations if necessary. **LW Band.**—Set oscillator and receiver to 1,000m (300kc) and adjust T9 and T4 for maximum output.

Set oscillator and receiver to 1,850m (162.2kc) and adjust L11 and L6 for maximum output.

# MARCONI 950, HMV 1750

Continued from page v

**MW Band.**—Switch receiver to MW, set condenser gang to minimum and inject a signal of 192m. Adjust T5 for maximum.

Tune receiver to 220m and inject a signal of that wavelength. Adjust T6 for maximum output.

Inject a signal of 530m and adjust the receiver pointer to this wavelength. Adjust the cores of L10 and L4 for maximum output.

**LW Band.**—Switch receiver to LW and tune receiver to 1,000m. Inject a signal of this wavelength and adjust T7 and T8 for maximum output.

Tune receiver to 1,750m, inject a signal of this wavelength, and adjust the cores of L11 and L6 to maximum output.

### Press-button circuits

Remove the escutcheon, press button and adjust the top trimmer until the programme is heard. Adjust the lower trimmer for maximum.